



*International Technology
Corporate Finance*

How to Position WiMAX as a Complementary Service to LTE

Dr. Mehmet Unsoy

Partner, Cartagena Capital

April 22nd, 2008

**Next Generation Networks & Basestations Conference
Bath, U.K.**



Dr. Mehmet Unsoy

- Highly experienced telecommunications technology executive with 30 years experience in the data, IP and wireless industries
- Partner at Cartagena Capital, a global investment banking boutique, focused on telecom, specifically wireless companies
- Ex-CTO/ CIO, Vice President/ Chief Wireless Architect responsible for O2 (UK, Germany, Ireland and The Netherlands)
- Ex-VP Mobile Multimedia Architecture, British Telecom (UK)
- Former Director Wireless Internet, Nortel Networks – Asia/ Pacific, US and Global (US, Japan)
- Former R&D Director at Bell-Northern Research (Canada)
- Ph.D., University of Waterloo (Canada) and BSEE degree from METU in Ankara



Cartagena Capital

- Investment banking boutique <http://www.cartagena-capital.com>
- Headquartered in Munich, Germany, with partners in Munich, Paris, Helsinki and Dallas, Texas
- Focus on Telecom sector, with special emphasis on wireless market
- Key services: Mergers and Acquisitions (M&A) and Fundraising
- Several recent transactions:
 - Swapcom (mobile device management) sold to Swisscom subsidiary Sicap
 - Part of Openbit (mobile payment) sold to Packetvideo
 - Coronis (machine-to-machine) sold to Elster
 - Merger of Appium (SIP app server) with Aepona
- Working on a number of transactions in various areas:
 - WiMAX and LTE
 - FMC / Mobile VoIP
 - Mobile Video / TV
 - Mobile Security / Mobile Signature

Outline

- **Road to Broadband Wireless**
- **Comparison of HSPA, WiMAX and LTE**
- **Market Positioning**
- **Drivers for Technology Choices**
- **Conclusions**

Broadband Wireless Direction

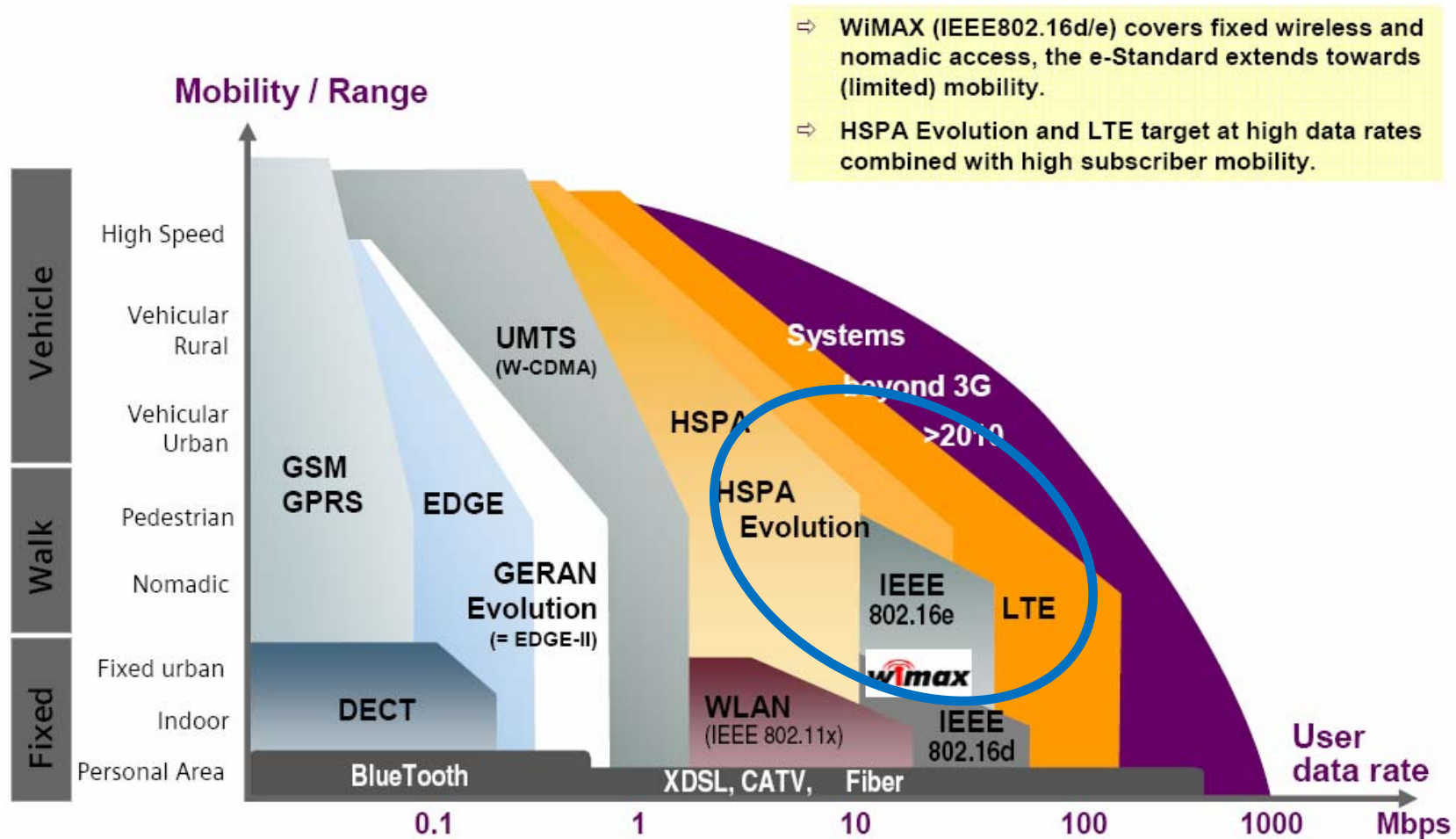

- ⇒ WiMAX (IEEE802.16d/e) covers fixed wireless and nomadic access, the e-Standard extends towards (limited) mobility.
- ⇒ HSPA Evolution and LTE target at high data rates combined with high subscriber mobility.

The 3GPP vs. IEEE Standardization Efforts



- 3GPP – collaboration of standards bodies comprising 400 members mostly mobile operators and equipment manufacturers for mobile operators
- 3GPP defines standards for GSM, WCDMA / UMTS, as well as HSDPA, HSPA, and LTE
- IEEE is an open forum of standardization group
- IEEE 802.11 group produced Wi-Fi standards, and IEEE 802.16 group focused on WiMAX
- WiMAX Forum is a 400+ member industry forum to promote and certify compatibility and interoperability of WiMAX products

Evolution of Broadband Wireless

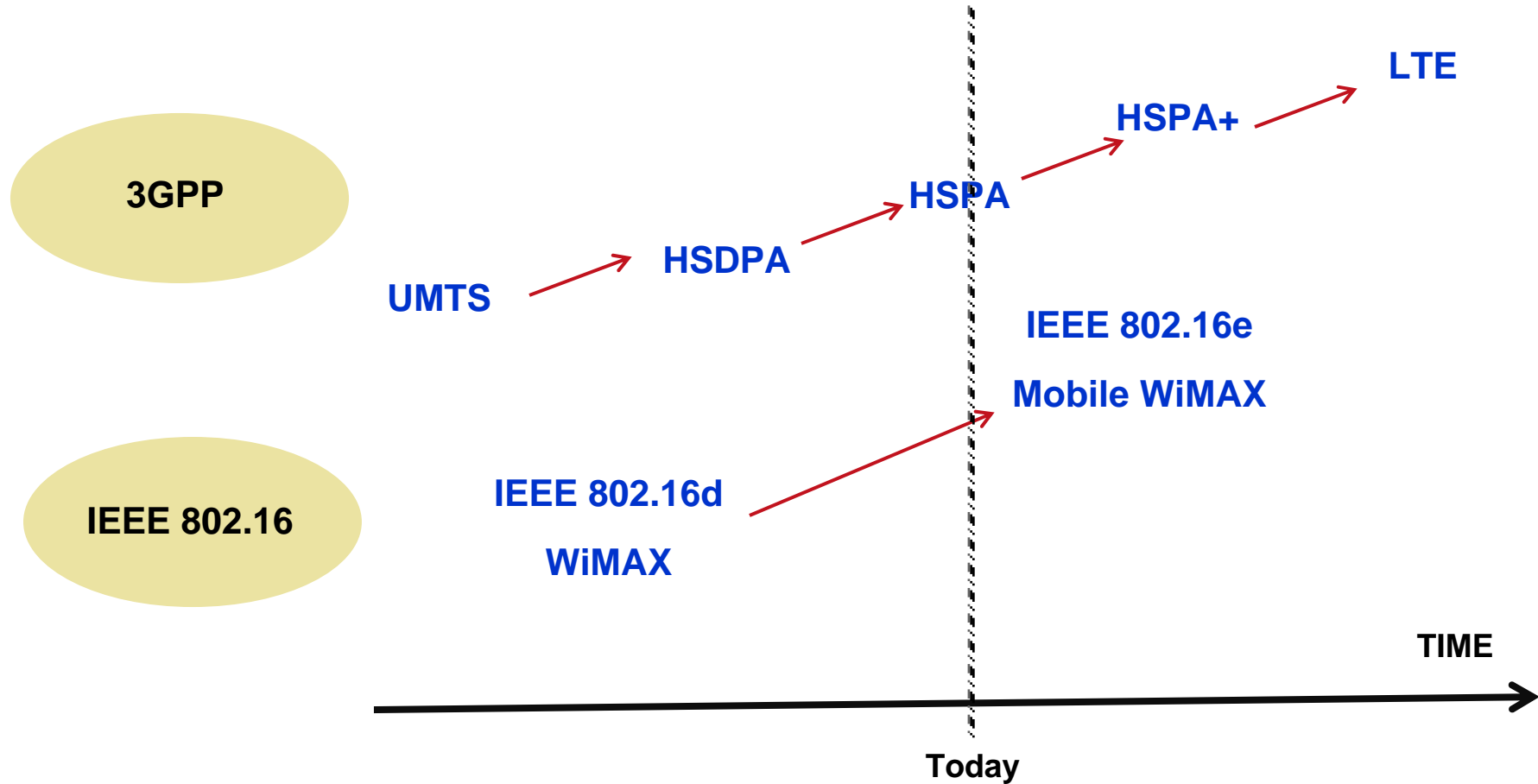

HSPA vs. WiMAX Comparison

	HSPA	WiMAX	Comments
Signal Format	DL Code Aggregation UL DS-CDMA	OFDMA for both DL & UL	Different formats; higher uplink efficiency with WiMAX
Duplex Scheme	FDD, and optionally TDD	TDD, but FDD in the works	TDD is more spectrally efficient; but FDD fits better with spectrums available around the world
Frequency Bands	700 MHz to 2.6 GHz	700 MHz to 5.8 GHz	WiMAX has wider choices
Type of Spectrum	Licensed	Both Licensed and unlicensed	Wider choices with WiMAX; 700 MHz is new for both
Antenna Technology	MIMO optional	Adaptive MIMO Switching between different MIMO modes	Potentially similar, but WiMAX may offer better spectral efficiency
Handover	Network initiated Hard Handover	Network Optimized Hard Handover	For data traffic, soft handoff is not needed
Network Architecture	R7: Flat IP architecture optional	Flat IP architecture	HSPA is in transition / evolution; WiMAX starts IP architecture

Performance comparisons vary depending on who you ask!

But they are probably somewhat comparable!!

WiMAX and LTE Comparison

	LTE	WiMAX	Comments
Signal Format	DL OFDMA UL SC-FDMA	OFDMA for both DL & UL	DL the same; LTE claims better solution with SC-FDMA for UL
Duplex Scheme	FDD + TDD FDD focus	TDD + FDD TDD focus	TDD is more spectrally efficient; but FDD fits better with spectrums available around the world
Frequency Bands	700 MHz to 2.6 GHz	700 MHz to 5.8 GHz	WiMAX has wider choices
Type of Spectrum	Licensed	Both Licensed and unlicensed	Wider choices with WiMAX; 700 MHz is new for both
Antenna Technology	eNodeB: 1,2,4; UE:2 Close + open Loop	BS: 1,2,4; MS 1,2 Close + open Loop	Potentially similar
Channel Bandwidth	1.25 to 28 MHz	1.25 to 20 MHz	Both very flexible
Network Architecture	Flat IP architecture eNodeB + aGW	Flat IP architecture BS + ASN GW	Same or very similar

High degree of technology commonality – anywhere from 75 to 90%

But there seems to be lots of IP issues!!

Architecture Comparison

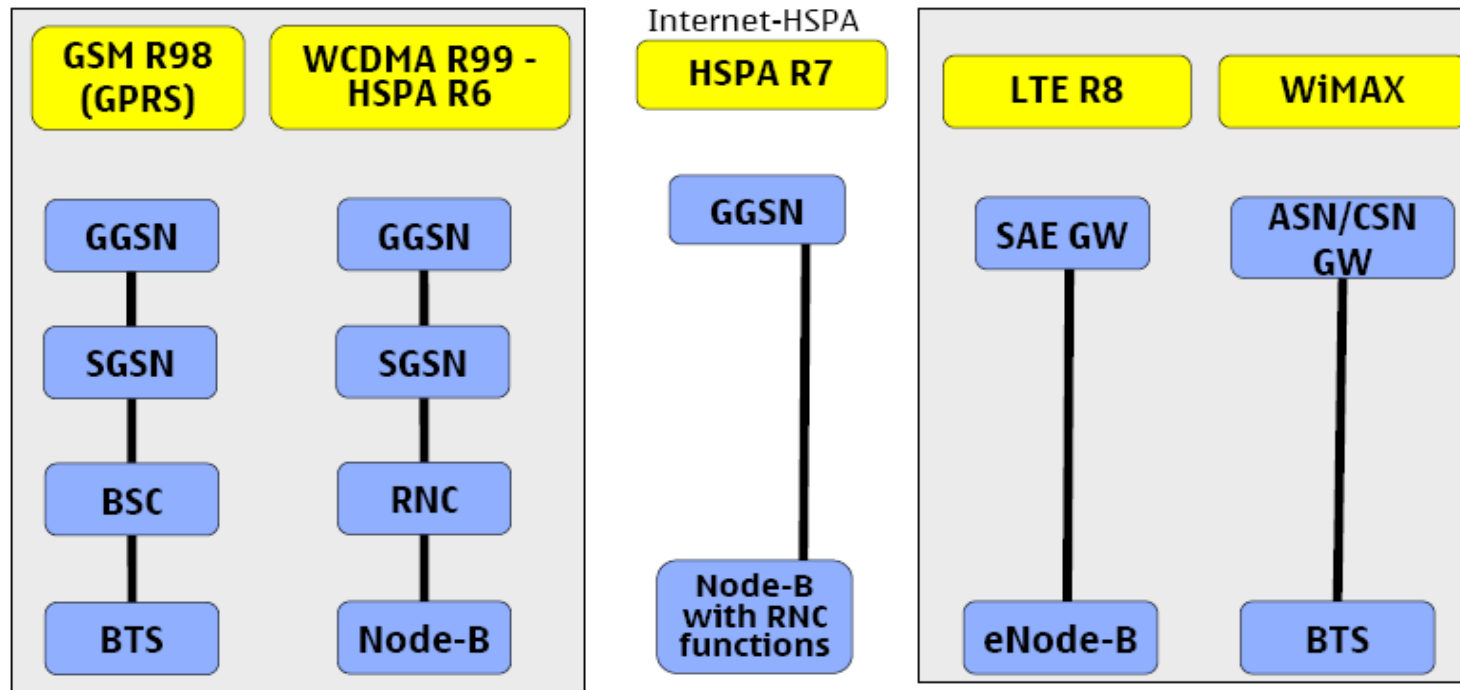

Source: Nokia Siemens Networks

Operator Considerations for Technology Selection

- **Incumbent vs Greenfield**
 - European 3G operators vs new players in India
- **Service Offering**
 - Portal / Mobile Internet Access
- **Competitive Situations**
 - Verizon vs AT&T
- **Technology Evolution Paths**
 - WCDMA -> HSDPA -> HSPA -> HSPA+ -> LTE
- **CAPEX / OPEX considerations**
 - WiMAX may offer lower CAPEX / OPEX due to several reasons

Regulatory Considerations for Technology Selection

- **Spectrum availability**
 - 425+ BWA license holders around the world, also lots of unlicensed spectrum
 - Spectrum auctions in Europe, Japan, USA, etc
- **Cost of spectrum**
 - May depend on competition, more than anything else
- **Regulatory compliance**
 - Certain spectrum are only usable for 3G / 4G
 - WiMAX being part of 3G / 4G picture, solves the problem
- **Standards compliance**
 - Availability of products certified by WiMAX Forum; certification starts in Q2 2008
 - Estimated 1000 products certified by WiMAX Forum by 2010

Developed vs. Developing Markets for Technology Selection

- **Fixed vs. Mobile Internet Access**
 - 300 Million Fixed Broadband users today, expected to grow to 600M in 3-4 years, but
 - 3.3 Billion mobile users with 100% penetration in 59 countries
 - Mobile Internet access market will be much bigger than Fixed Internet access market
- **Developed vs. Developing Markets**
 - Developing markets lack fixed broadband infrastructure
 - Need for fixed, portable & mobile Internet access with one infrastructure
 - WiMAX fits the bill for developing market requirements
- **Range of applications over IP**
 - All or almost all applications can be provided with flat IP architectures
 - VoIP, Internet access, Video, etc

WiMAX Forum estimates 133 Million WiMAX Users by 2012

Much more than 50% could be in developing markets!

Why Complementary?

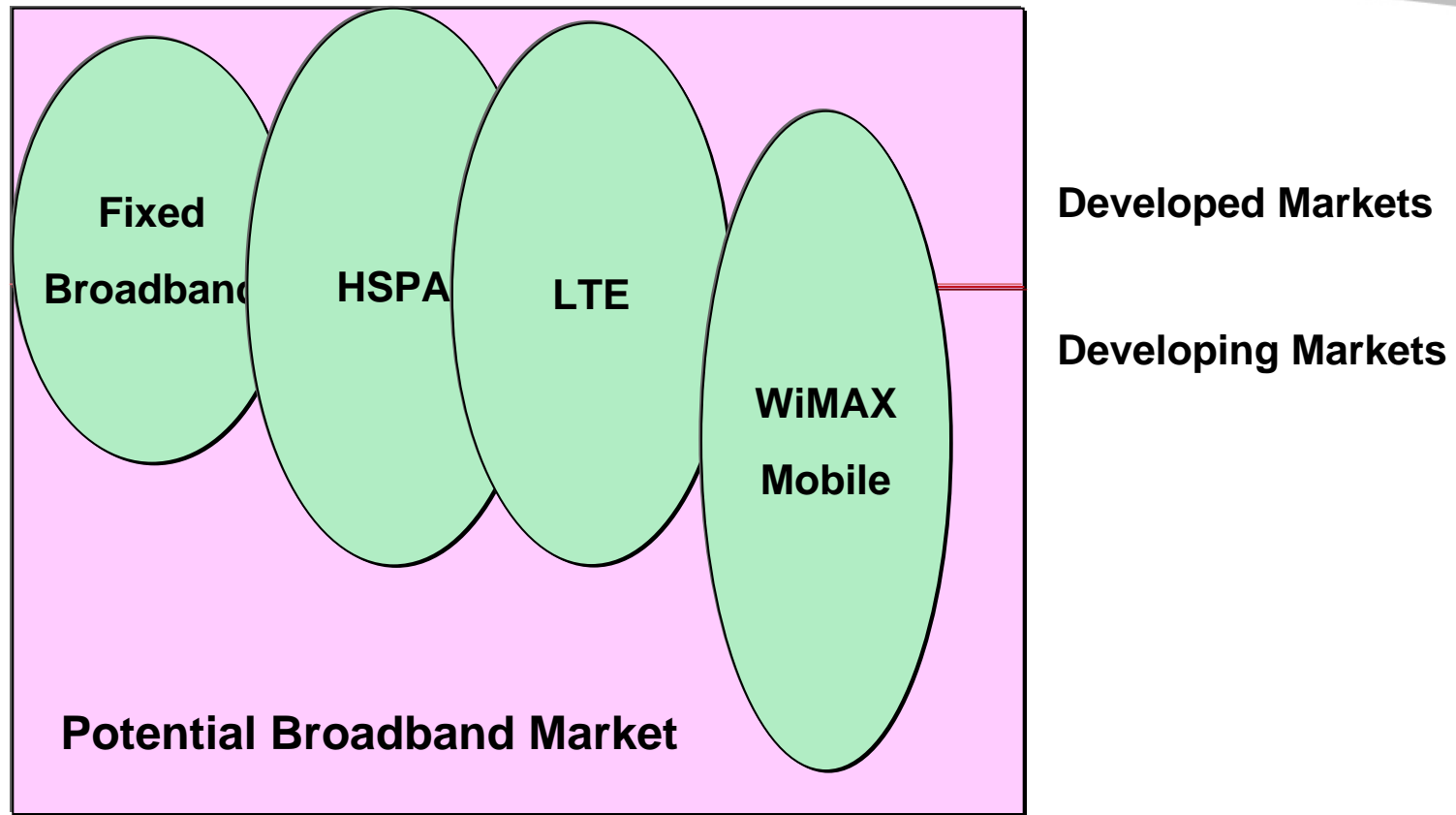

Rivalry within the family, e.g. sibling rivalry?

Maybe main competition is between Fixed and Wireless Broadband!

Can WiMAX be TDD portion of LTE?

- **WiMAX Mobile is primarily focused on TDD**
- **LTE is focusing on FDD for the early version**
- **3GPP may adopt WiMAX Mobile as the basis or one version of the TDD**
- **Various industry leaders / experts are supporting such a direction**
- **Near future will show whether the industry has the willingness to achieve such convergence!**

Implications for Innovation

- **Broadband Wireless will be a huge global market**
- **Target Fixed Mobile Convergence (FMC) with broadband wireless playing a significant role**
- **Offer solutions that work across or on all types of broadband wireless technologies**
- **If possible/ appropriate, make your value proposition agnostic of different types of broadband technology choices**
- **Explore and offer solutions for interoperability between different broadband technologies**
- **Consider solutions for hybrid scenarios**

Conclusions

- **LTE and WiMAX Mobile have strong commonalities in technology; however there are IP issues**
- **WiMAX Mobile is available in 2008, but LTE is at least 2 years away**
- **HSPA and WiMAX Mobile today are somewhat comparable, but HSPA choice makes sense for those with existing WCDMA / UMTS networks today**
- **For greenfield operators targeting broadband wireless today, WiMAX Mobile is a very good if not best choice**
- **Developing countries / markets present more broadband wireless opportunities with WiMAX Mobile today**
- **WiMAX could be / should be (?) part of LTE**

Questions?



Contact:

Dr. Mehmet Unsoy

Partner

Cartagena Capital GmbH

Phone: +1 972 818-2923

Mobile: +1 469 358-5302

Web: www.cartagena-capital.com

E-Mail: mehmet@cartagena-capital.com